

# ASTRA VAN

## PRICES AND OPTIONS

2019.5 models. Prices effective 22 March 2019



# ASTRA VAN RANGE HIGHLIGHTS

## ASTRA VAN SPORTIVE

### Highlights

- Satellite navigation
- Smartphone projection
- Forward collision alert
- Traffic sign recognition
- Lane departure warning / lane assist

### Infotainment:

- R4.0 Navi IntelliLink
- DAB/FM/AM Radio
- 7-inch colour touchscreen
- Satellite navigation
- Smartphone connectivity for your phone, messaging, music, maps and apps
- Apple CarPlay™ and Google Android Auto™ app projection
- Siri / Google Now voice command for phone, messaging, music, maps and calendar
- Steering wheel controls for phone, music and cruise control
- Bluetooth® phone, messaging and music streaming
- USB connection
- Six speakers

### Interior/styling features:

- Height-adjustable head restraints
- Steering column adjustable for reach / rake
- Leather-covered steering wheel
- Sports-style front seats
- Driver's ergonomic active seat (AGR-approved\*)
- Adjustable front armrest

### Exterior/styling features:

- Electrically operated front windows
- Electrically adjustable/heated door mirrors
- Remote control central locking
- Door-to-door illumination
- Tyre inflation kit in lieu of spare wheel
- Automatic lighting / wipers
- Automatic anti-dazzle rear-view mirror
- Front fog lights
- 17-inch 5 twin-spoke alloy wheels

### Safety features:

- Electronic Stability Programme (ESP)
- Anti-lock Braking System (ABS)
- Hill start assist
- Six airbags
- Tyre pressure warning light
- Half-height steel bulkhead
- Driver Assistance Pack One
  - Forward collision alert
  - Traffic sign recognition
  - Follow distance indicator
  - Lane departure warning / lane assist
- Remote control alarm system

\*AGR (The Campaign for Healthier Backs) is an independent centre of excellence for ergonomics, based in Germany.

# ASTRA VAN PRICES

Trim	Engine	Transmission	GVW (kg)	Payload (kg)	RRP inc. VAT & VRT €*
<b>DIESEL ENGINES</b>					
<b>Sportive</b>	1.6CDTi (136PS) S/S	Manual	1875	590	<b>25,295</b>
<b>Sportive</b>	1.6CDTi (136PS)	Automatic	1900	611	<b>26,295</b>

\*Please note there will be an additional conversion charge invoice for €550 plus vat in addition to the above charge for the vehicle. S/S = Start/Stop.

The above is for information purposes only as our products are continually updated and changes may be made to the specifications at any time. If you require any specific feature, you must consult your authorised Opel Dealer who is regularly updated with any change in specification. Specifications are subject to change without notice.

RRP does not include recommended delivery charge of €700 or Conversion charge of €550. This price includes the recommended cost of PDI, number plates and delivery to an Opel Dealer.

The recommended delivery charge does not include fuel supplied by the Dealer, Motor insurance or any other goods or services supplied by agreement between the Dealer and the customer.

Prices effective 22.3.19. Prices subject to alteration or change without notice or obligation.

## OPTIONS Recommended Retail Prices including Taxes

	Sportive	
<b>OPTION PACKS</b>		
<b>IntelliLux LED Matrix headlights</b> • Dipped beam • Main beam and dynamic lighting (16 electronically controlled LED lights) • Front camera system • Intelligent main beam control • Automatic headlight levelling • LED tail lights	○	<b>€1350</b>
<b>Parking Pack</b> <sup>1</sup> • Front and rear parking distance sensors • Advanced park assist • Side blind spot alert • Electrically foldable door mirrors • Rear-view camera	○	<b>€1000</b>
<b>Winter Pack</b> • Heated leather-covered steering wheel • Heated front seats	○	<b>€500</b>
<b>Towing Pack</b> • Detachable tow bar • Trailer stability programme	○	<b>€800</b>
<b>INTERIOR OPTIONS</b>		
Dual-zone electronic climate control incorporating air conditioning	○	<b>€400</b>
Keyless entry and start	○	<b>€550</b>
Electric parking brake	○	<b>€300</b>

	Sportive	
<b>EXTERIOR AND CONVENIENCE OPTIONS</b>		
Power tilt and slide sunroof	○	<b>€650</b>
Front and rear parking distance sensors <sup>2</sup>	○	<b>€250</b>
LED tail lights <sup>3</sup>	○	<b>€300</b>
17-inch Gloss Black five twin-spoke alloy wheels	○	<b>€150</b>
18-inch five twin-spoke alloy wheels	○	<b>€550</b>
Steel emergency spare wheel (in lieu of emergency tyre inflation kit) <sup>4</sup>	○	<b>€150</b>
Brilliant paint	○	<b>€155</b>
Two-coat metallic paint	○	<b>€600</b>
Premium paint	○	<b>€750</b>
<b>AUDIO AND COMMUNICATION OPTION</b>		
CD drive	○	<b>€165</b>

Prices effective as of 1.3.19. Prices are subject to alteration without notice or obligation.

○ = Optional at extra cost.

<sup>1</sup> = Not available in conjunction with front and rear parking distance sensors. <sup>2</sup> = Not available in conjunction with Parking Pack. <sup>3</sup> = Standard with optional IntelliLux LED Matrix headlights. <sup>4</sup> = Loadspace capacity is reduced.

# TECHNICAL DATA

## FUEL ECONOMY AND EMISSIONS



	Wheel size (inches)	Performance (manufacturer's figures)		Fuel economy litres/100km <sup>#</sup>		CO <sub>2</sub> emissions g/km <sup>#</sup>	
		Maximum speed (km/h)	Acceleration 0-100km/h (sec)	Combined Low	Combined High	Combined Low	Combined High
<b>Manual</b>							
1.6 (136PS) Turbo D Start/Stop	17/18	212	8.8	4.8	5.4	127	142
<b>Automatic</b>							
1.6 (136PS) Turbo D Start/Stop	17/18	208	9.4	5.4	5.9	140	154

<sup>#</sup>Fuel consumption and CO<sub>2</sub> emissions figures are determined according to the WLTP test cycle. Full data relating to WLTP test cycles can be found at: [www.opel.ie/wltp](http://www.opel.ie/wltp) Figures are intended for comparability purposes only. The fuel consumption you achieve under real life driving conditions and CO<sub>2</sub> produced will depend upon a number of factors, including the accessories fitted after registration, variations in driving styles, weather conditions and vehicle load. Only compare fuel consumption and CO<sub>2</sub> with other vehicles tested using the same technical procedures. For more information contact your local Opel Dealer.

## DIESEL ENGINE

	1.6CDTi (136PS) Turbo diesel Start/Stop
Capacity	1598cc
Maximum power	136PS (100kW) @ 3500-4000rpm
Maximum torque	320Nm (236 lb.ft.) @ 2000-2250rpm
Configuration	4 cylinders, 4 valves per cylinder, double overhead camshafts
Fuel/induction system	Variable geometry turbocharger with intercooler. Common rail fuel injection
Emissions compliance	Euro 6d-TEMP (6.2) with Diesel Particulate Filter
Service intervals	30,000km or one-year (whichever occurs sooner)

## TYRE RATING

Tyre size	Fuel efficiency group	Wet grip performance	External noise	
			Measured (dB)	Group
225/45 R 17	C	A-B	71	
225/40 R 18	E	B	70	

Tyre rating according to EU Regulation 1222/2009

## Steering

- Power-assisted steering
- Turning circle (wall-to-wall):
  - 11.05m (36.2ft.)

## Body

**Aerodynamic drag co-efficient:**  
Astra Van – Cd 0.285

**Fuel tank capacity**  
48 litres (10.5 gallons)

## Warranties\*

Every Astra Van comes with:

- A three-year/100,000km manufacturer's warranty
- Opel Assistance for 12 months from first registration
- 12-year body panel anti-perforation warranty

\* = Warranty is only available on vehicles sourced from authorised Opel Ireland Dealers. Terms and conditions apply – please see your Opel Dealer for details.

## Transmission

**Six-speed manual gearbox**

**Six-speed automatic transmission with ActiveSelect® function**

A six-speed automatic transmission is optional. On the road, a wide selection of shift patterns is adapted to the style and habits of the driver, anticipating when maximum acceleration or maximum efficiency is required. The electronic control will also adapt to the prevailing road conditions, reducing gear shifting when climbing or

descending and using engine braking assistance during down changes. The ActiveSelect® manual mode allows the gear lever to be used like a sequential manual gearbox – you simply push the lever forward or back to change up or down the gears. The driver also benefits from a 'neutral' gear disengagement at idle, which reduces vibration and contributes to improved fuel consumption.

## Braking and stability

- Electronic Stability Programme (ESP)
- Cornering brake control
- Straight line stability control
- Rollover mitigation
- Drag torque control
- Hill start assist
- Anti-lock Braking System (ABS)
- Emergency brake assist
- Fading brake support
- Electronic brakeforce distribution
- Adaptive brake lights

**Front ventilated discs:** 300mm diameter

**Rear discs:** 264mm diameter

## Suspension

**Front:** Independent. Lightweight MacPherson struts with gas-pressure dampers and coil springs. Anti-roll bar.  
**Rear:** Lightweight compound crank rear axle with one-piece, hollow cast trailing arms. Built-in anti-roll bar. Progressive-rate double conical mini-block springs and gas-pressure dampers.

# ASTRA VAN

## EXTERIOR DIMENSIONS MM (INCHES)

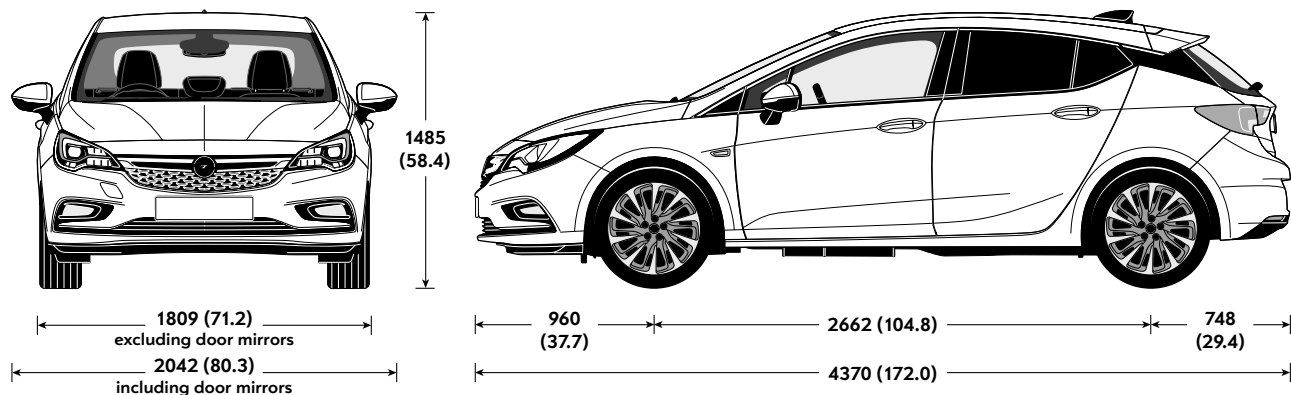

Height shown unladen.

## INTERIOR DIMENSIONS MM (INCHES)

Loadspace	
Maximum length	1550 (61.0)
Maximum width	1350 (53.1)
Maximum height	880 (34.6)
Width between wheel arches	1001 (39.4)

Rear Tailgate	
Aperture height	600 (23.6)
Aperture width	1015 (39.9)
Loading height (unladen)	458 (18.0)

LOADSPACE VOLUME CU.M (CU.FT.)	
VDA method	1.41 (49.8)

## WEIGHTS AND TOWING DATA

	Plated weights and kerbweight kg				Towing weights Trailer with brakes Payload kg (without brakes) kg	Plated Gross Combination Weights (GCW) kg	
	Front axle Plated	Rear axle Plated	GVW	Total Minimum Mass			
<b>ASTRA VAN</b>							
<b>Sportive 1.6CDTi (136PS) Start/Stop</b>	980	910	1875	1285	590	1650 (650)	3400
<b>Sportive 1.6CDTi (136PS) automatic</b>	1020	900	1900	1289	611	1700 (650)	3400

**Note:** Minimum Mass ('Mass in running order' on Certificate of Conformity and 'Mass in Service' on V5C form) is defined according to European Type Approval and include all fluids, tools, 90% fuel load and driver (75kg). It is minimum mass for this variant and does not consider local specification/trim. Weights are also subject to manufacturing tolerances (EU Legislation allows 5% tolerance). Payload figures do not allow for the weight of the driver, or any passenger's, which should therefore be deducted from the figures shown. **Gross plated weights** (including axle weights) quoted on the vehicle plate are to UK and Ireland plated weight specification and must never be exceeded. **Roof load** should not exceed 75kg including the weight of the roof rack/carrier.